

Optimization/Efficiency Open Forum Discussion/Bull Session

Sequence of Events

- Discuss Format
- Discuss Optimization
- Review Talking Points
 - Talking points are intended to seed conversation, not restrain it.
- Split
- Discuss in small groups ~ 40 minutes
- Report high points in big group ~ 15 minutes

FEB
26

2026 Wisconsin Section Operations Seminar



Optimization/Efficiency Open Forum Discussion/Bull Session

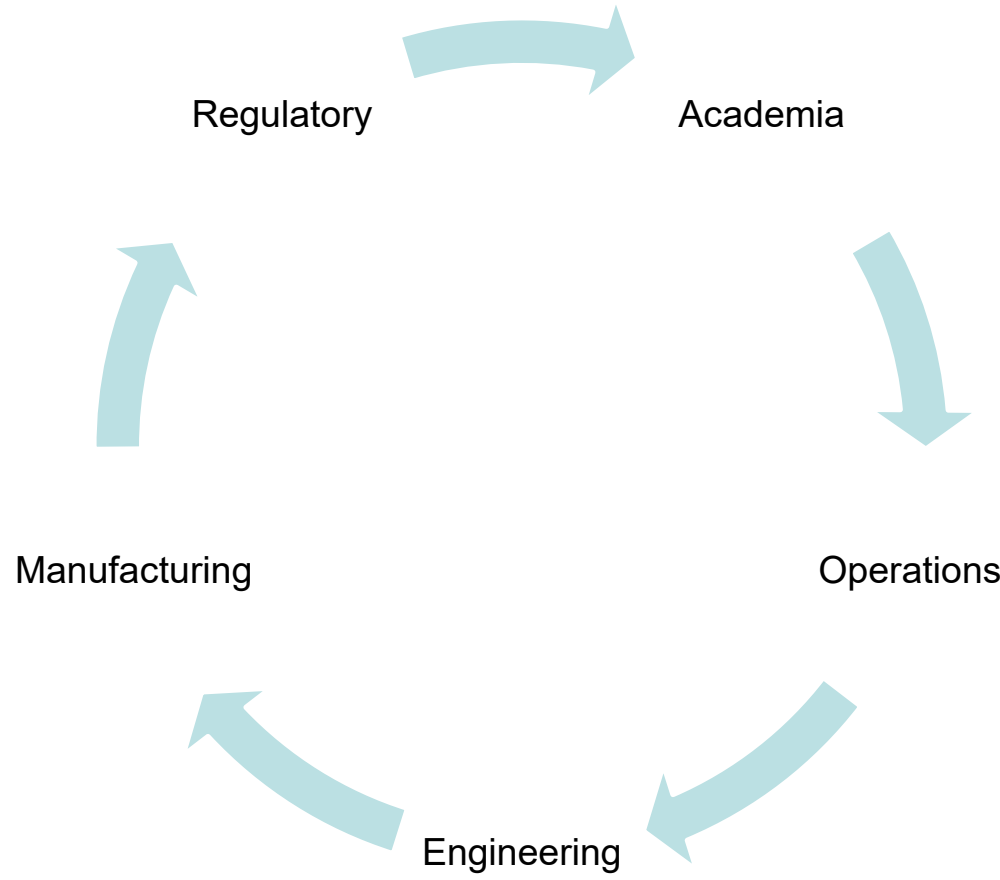

FEB
26

2026 Wisconsin Section Operations Seminar



Optimization Mindset Provides Many Benefits

- **Op-ti-mi-za-tion**; the action of making the best or most effective use of a situation or resource.



Save Money

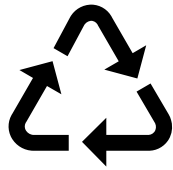

Improve Biosolids

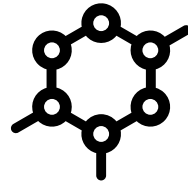

Reduce Chemical



Reduce Labor



Reduce Power



Develop Workflow



Streamline Maintenance

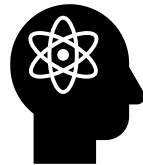

Capture Knowledge



Avoid "Emergencies"



Manage Runtime

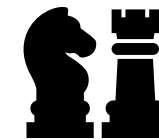

Refine Strategies

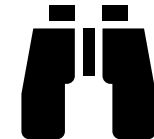

Reduce Blind Spots

FEB
26

2026 Wisconsin Section Operations Seminar



Optimization/Efficiency Open Forum Discussion/Bull Session

Plant and Process Efficiency

- What areas of your plant/facility/ processes have you identified as targets for optimization and efficiency and why
- At your facility is there a focus on improving plant efficiency? Why or why not?
- Who at your facility provides input or works to improve plant efficiency?
- What funding sources have you utilized for improving efficiency?
- What is an example of something at your facility you did that was low cost but had a significant effect on your process/plant efficiency?

FEB
26

2026 Wisconsin Section Operations Seminar



Optimization/Efficiency Open Forum Discussion/Bull Session

Energy/ Resource Recovery

- How do you identify inefficiencies at your facility?
- What tools/resources are available to identify room for improvement?
- What has been your experience with energy and resource recovery from wastewater?
- Does your facility have onsite power generation capabilities either from renewables or biogas?
- When planning capital improvement projects, how do you incorporate plant/process efficiency into your design choices?

FEB
26

2026 Wisconsin Section Operations Seminar



Optimization/Efficiency Open Forum Discussion/Bull Session

Musical Chairs – Split

- Students
- Committee Members
- Coworkers
- Speakers

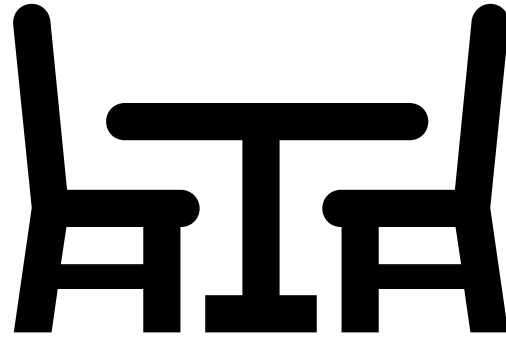

FEB
26

2026 Wisconsin Section Operations Seminar



Optimization Mindset Provides Many Benefits

- **Op-ti-mi-za-tion**; the action of making the best or most effective use of a situation or resource.



Save Money

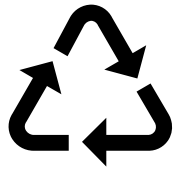

Improve Biosolids

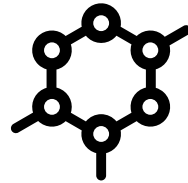

Reduce Chemical



Reduce Labor



Reduce Power



Develop Workflow



Streamline Maintenance

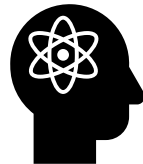

Capture Knowledge



Avoid “Emergencies”



Manage Runtime



Refine Strategies

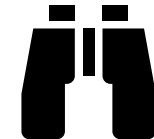

Reduce Blind Spots

FEB
26

2026 Wisconsin Section Operations Seminar





STRAND
ASSOCIATES®

Excellence in Engineering Since 1946

CSWEA Operations Seminar – Stevens Point, WI

February 26, 2026

Optimization of Low-Level Phosphorus Treatment New Glarus, WI Case Study

Troy Larson, Strand Associates, Inc.®



The content of this presentation is not to be downloaded, copied, used, or otherwise transmitted without the prior consent of Strand Associates, Inc.® and the Village of New Glarus.

Presentation Agenda

- Background
- Facility Upgrade
- Characterization Leads to Optimization
- Operation and Optimization

Optimization Mindset Provides Many Benefits

- **Op-ti-mi-za-tion; the action of making the best or most effective use of a situation or resource.**



Save
Money

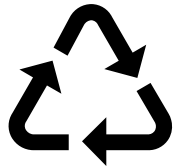

Improve
Biosolids

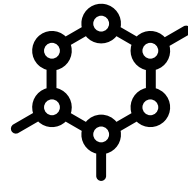

Reduce
Chemical



Reduce
Labor



Reduce
Power



Develop
Workflow



Streamline
Maintenance

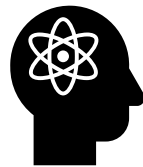

Capture
Knowledge



Avoid
“Emergencies”



Manage
Runtime



Refine
Strategies

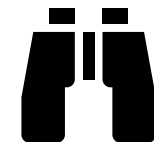

Reduce Blind
Spots

Optimize Your Optimization By Having a Plan

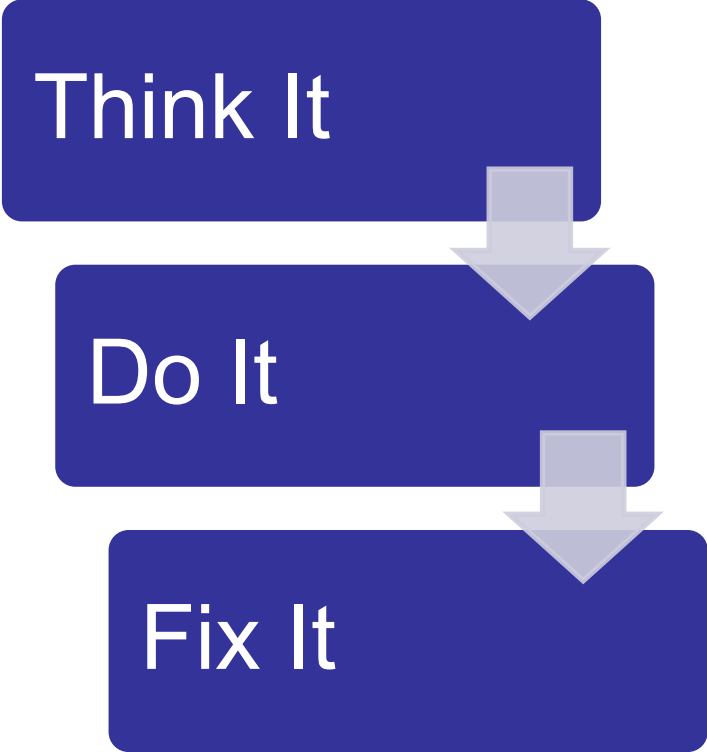

Optimize Your Optimization By Having a Plan

- Define the Problem (Goal)
 - Sometimes you give something to get something.
- Identify Variables
 - Collect Enough Information to Learn
- Determine the Feasible Domain
 - Observe Cause and Effect Relationships
 - Identify risk (cost) vs benefit
- Find Extremes
 - Anticipate extremes
 - Wet Weather
 - Clarifier Bulking
 - Other
- Conclude
 - This can be iterative, sometimes the conclusion is that you need to continue optimizing.

Tasks and Talents That Contribute To Optimization

- Study
 - Cause and Effect
- Collaborate
 - Learn from Others
- Experiment
 - With Focus and Guts
- Isolate
 - Reduce Noise
- Monitor
 - Track Data



Background

- Effluent Limit – 0.12 mg/L 6-month average
- Goal – Meet Limit with limited impact on BPR and sludge production

WWTP Background

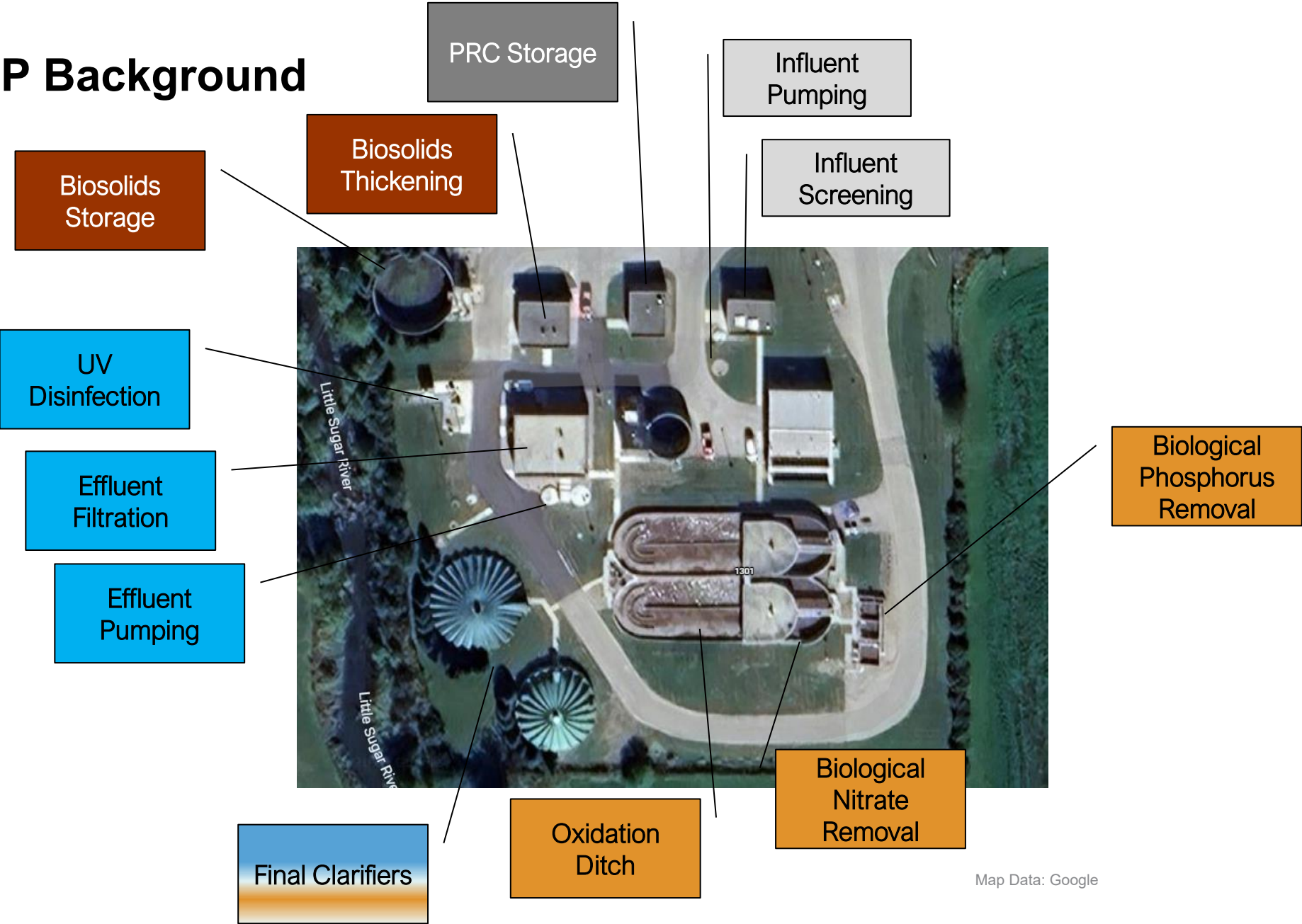

Map Data: Google

Successful Biological Phosphorus Removal For Decades Provided a Foundation for Low Level Compliance

- Biological phosphorus removal (BPR) successful in two project phases
 - Currently A2O
- Last upgrade moved BPR into a different configuration with more nitrate control
- Alum historically used for polishing
- Late summer often a problematic time for treatment

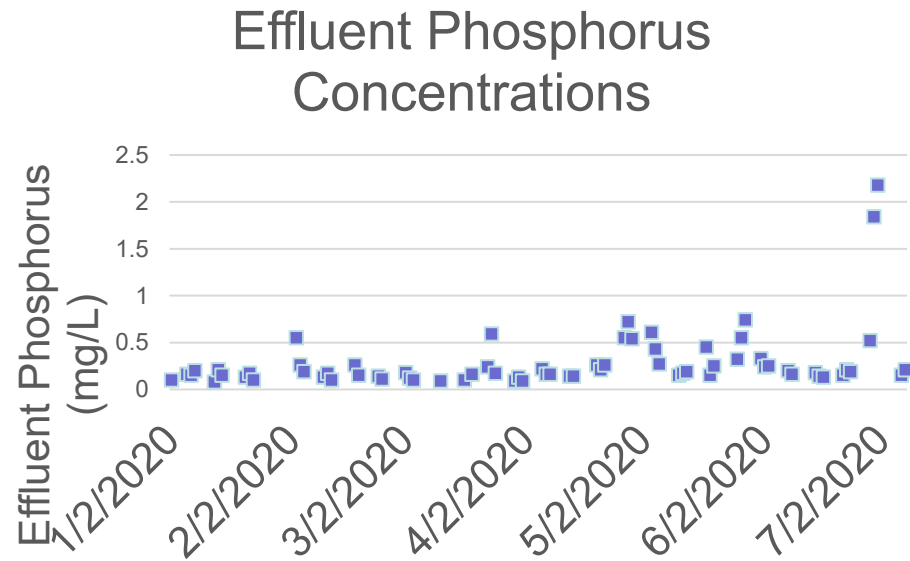

Facility Upgrade



Pumping Lifts The Secondary Effluent To An Elevation to Flow through Filters and UV Disinfection

Submersible Pumping Station

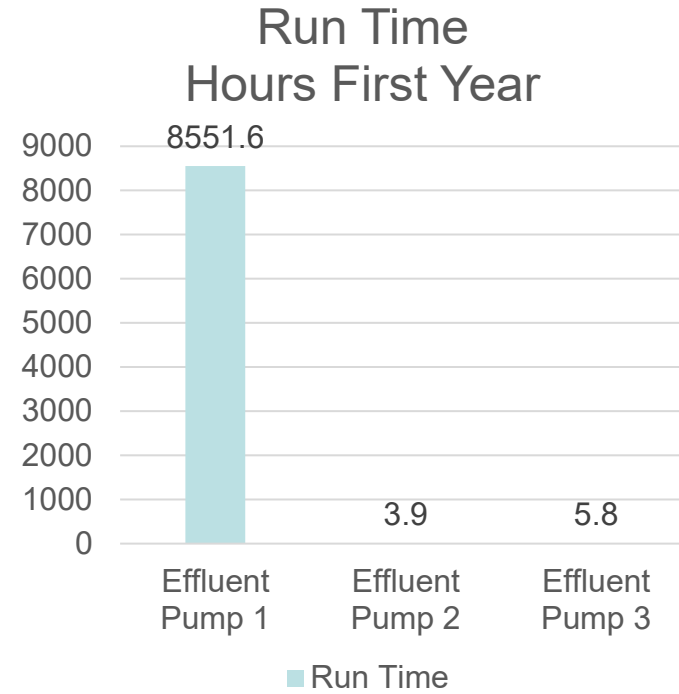
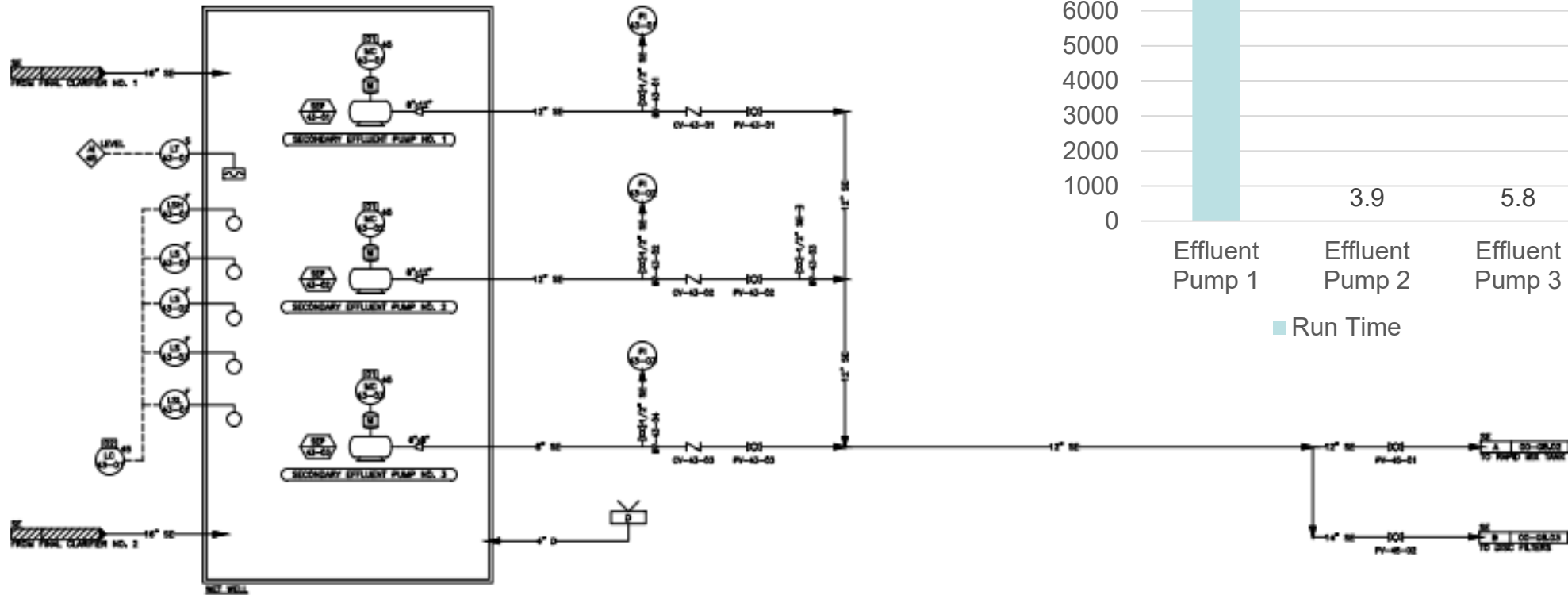

Rapid Mix, Coagulation, and Flocculation Tanks Aid in Chemical Treatment

PRC Addition

Polymer Addition

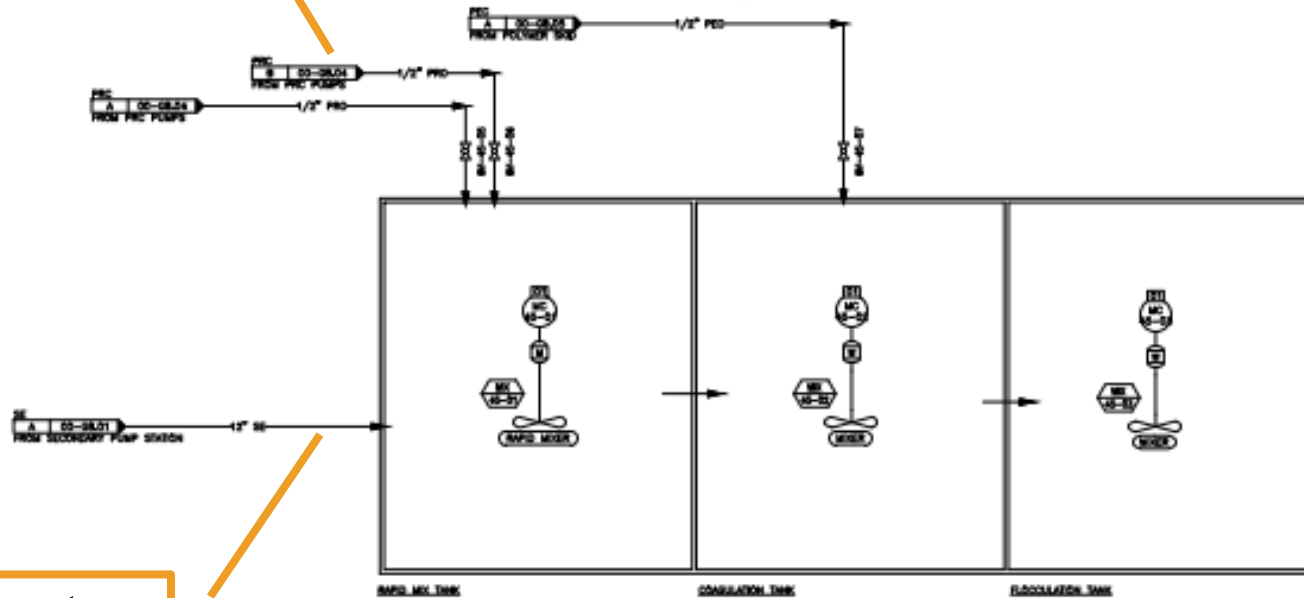

Secondary Effluent

Rapid Mix

Coagulation

Flocculation

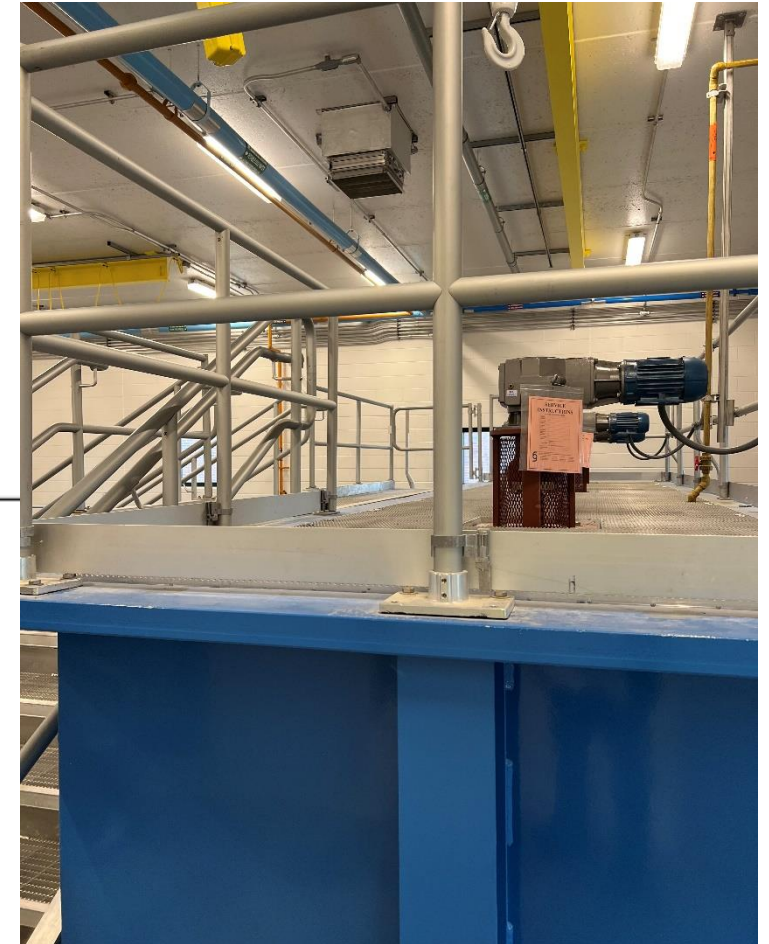

Filter Removes Both Secondary Effluent and Chemical Phosphorus Solids

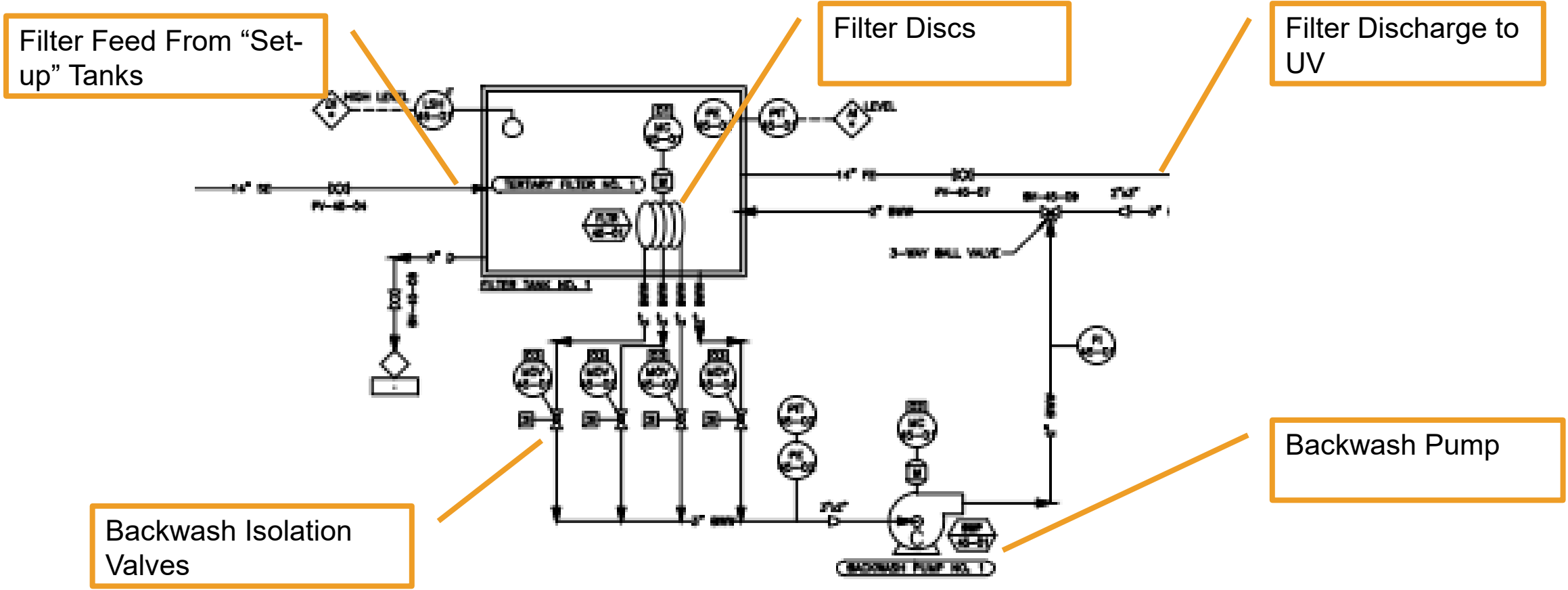

Flocculent Assists in Removing Small Solids



Automation Safeguards Performance and Optimizes Chemical Use

- Upstream Ortho Phosphate Measurement
 - Indicates reactive phosphorus to be treated
- Downstream Ortho Phosphate Measurement
 - Indicates reactive phosphorus remaining following treatment
- Down Stream Turbidity Meter
 - Indicates if small solids passed the filter
 - Polymer dosing can be adjusted accordingly
 - **Current Polymer Use at 0.5 gallons per day**

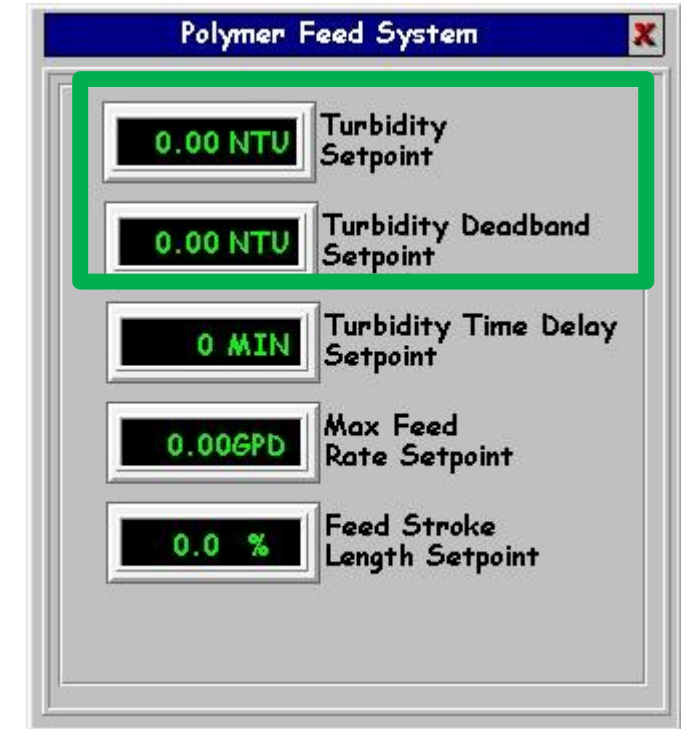
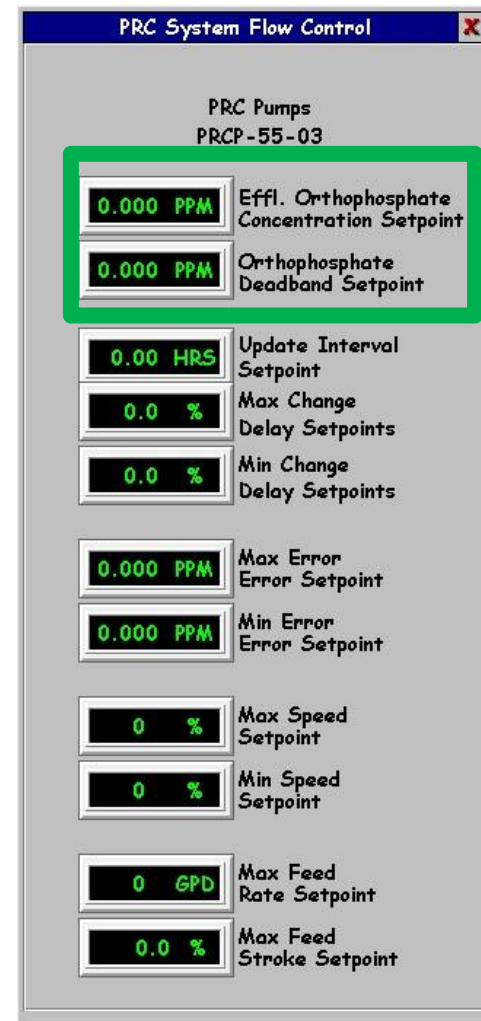

Characterization Leads to Optimization



Planning Era Data Collection Identifies Soluble and Particulate Total Phosphorus Fractions

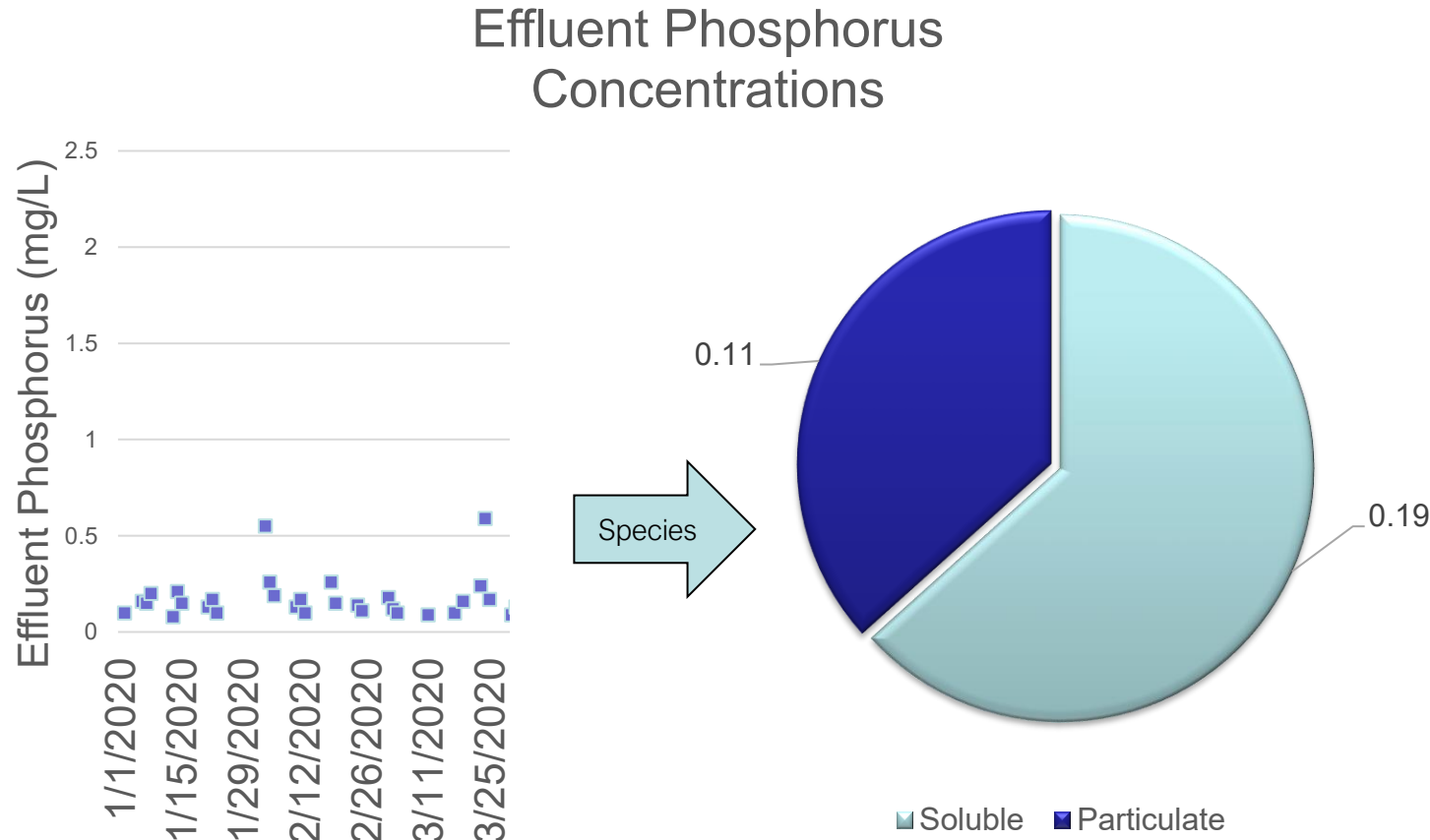

- Biological phosphorus removal produced 0.3 mg/L Effluent Total Phosphorus some of the year
- Effluent Phosphorus was determined to be about one third particulate and two thirds soluble/reactive

WWTP Has Many Locations That Impact Phosphorus Removal

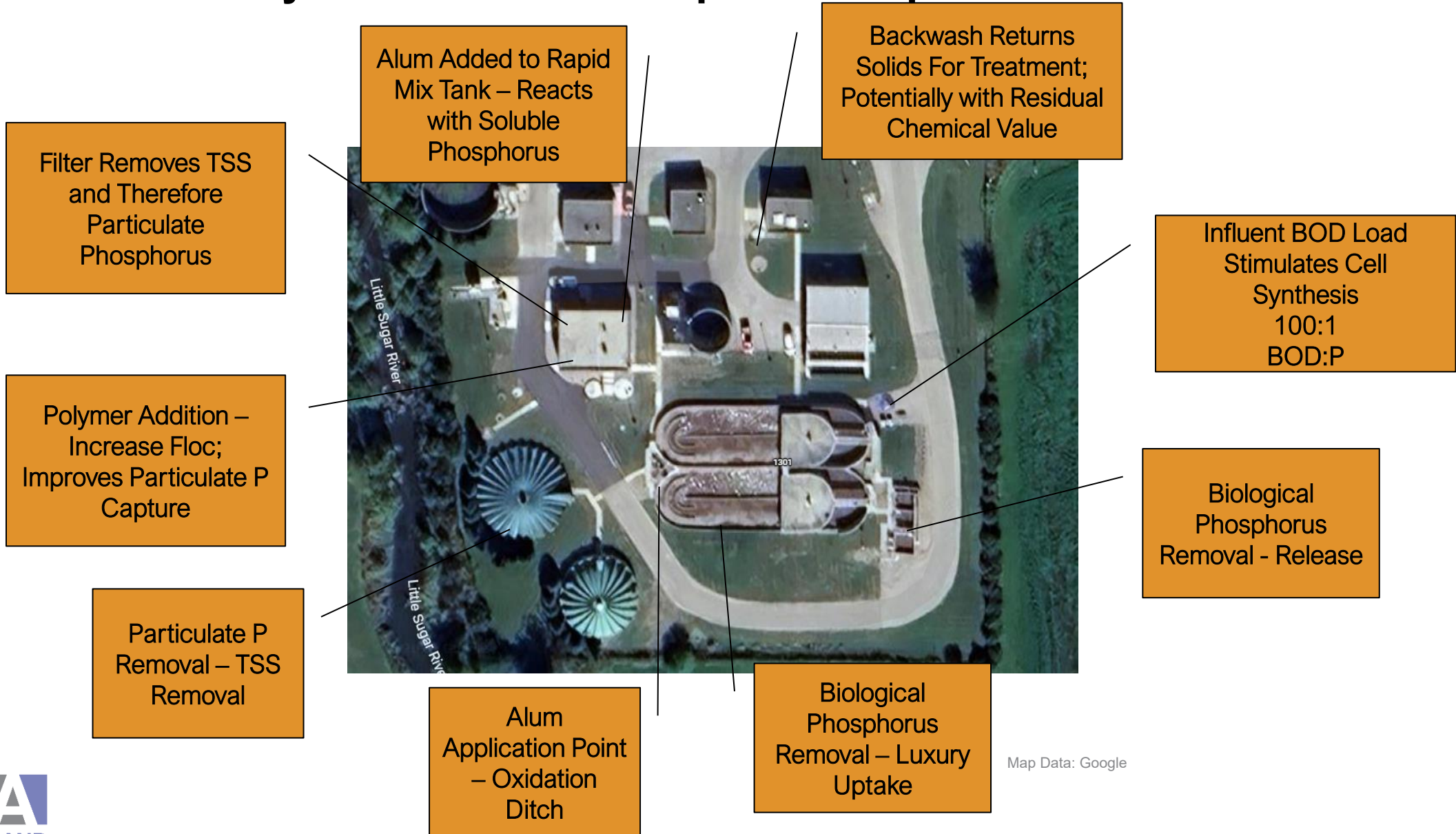

Map Data: Google

Understanding Entire Phosphorus Removal Process Aids In Optimization

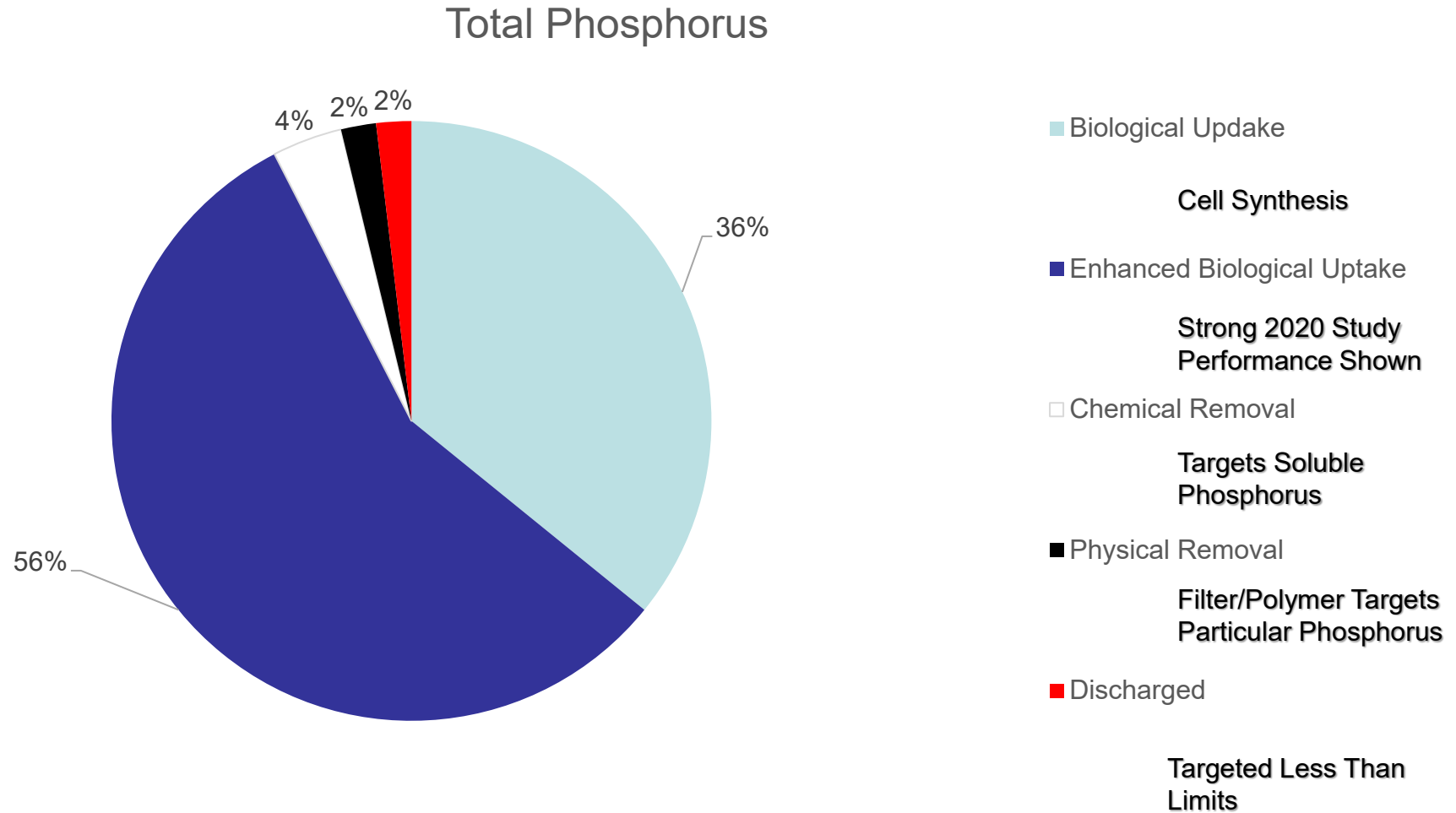

Understanding Entire Phosphorus Removal Process Aids In Optimization

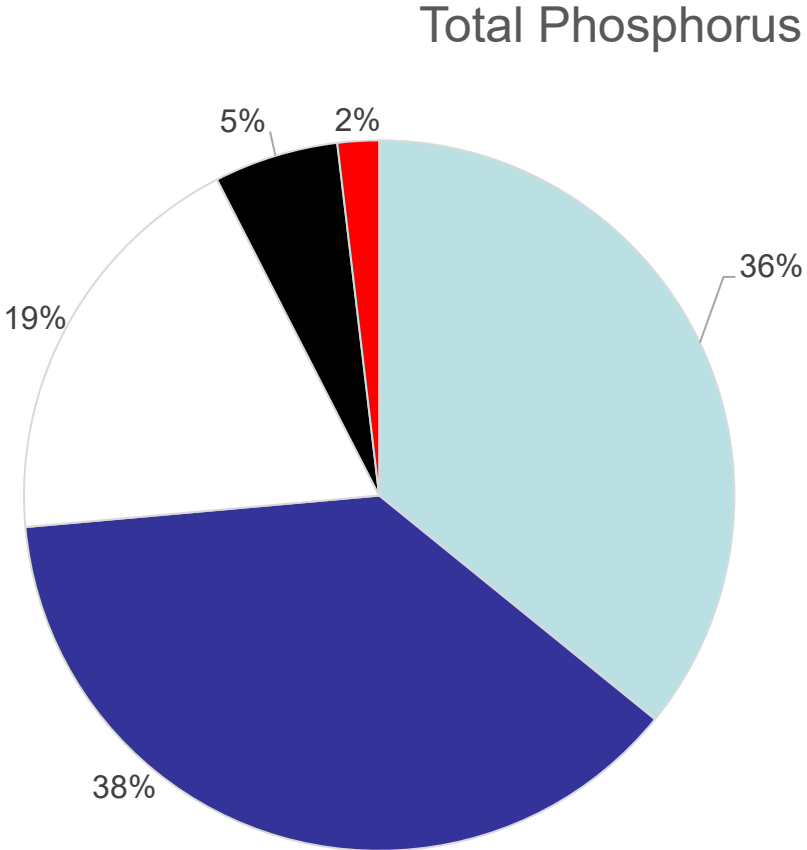

■ Biological Uptake

Cell Synthesis

■ Enhanced Biological Uptake

Typical Late Summer Performance

□ Chemical Removal

Targets Soluble Phosphorus

■ Physical Removal

Filter/Polymer Targets Particular Phosphorus

■ Discharged

Targeted Less Than Limits

Periodic Profile Analysis Monitors Biological Phosphorus Removal

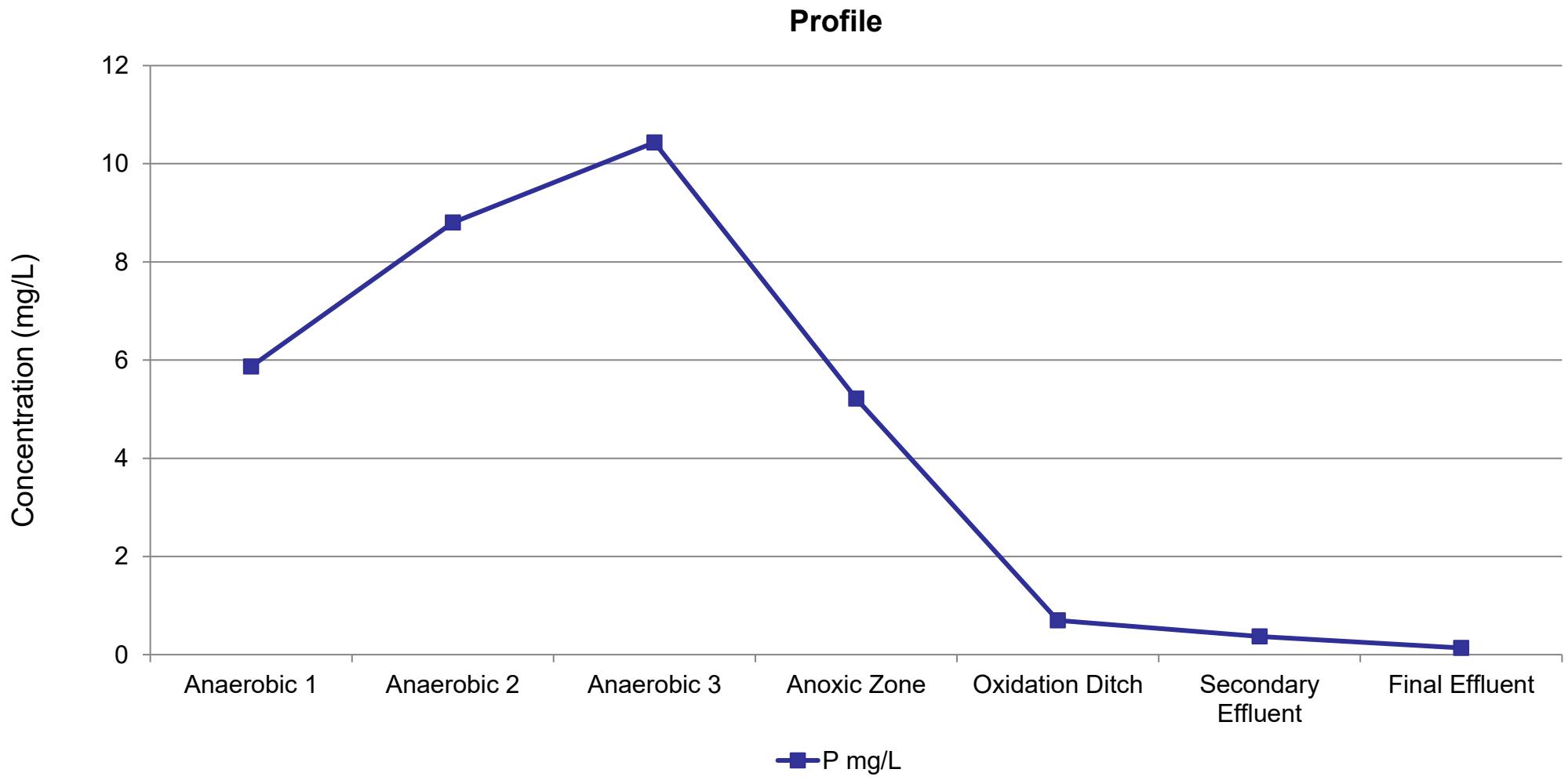

Understanding Entire Phosphorus Removal Process Aids In Optimization

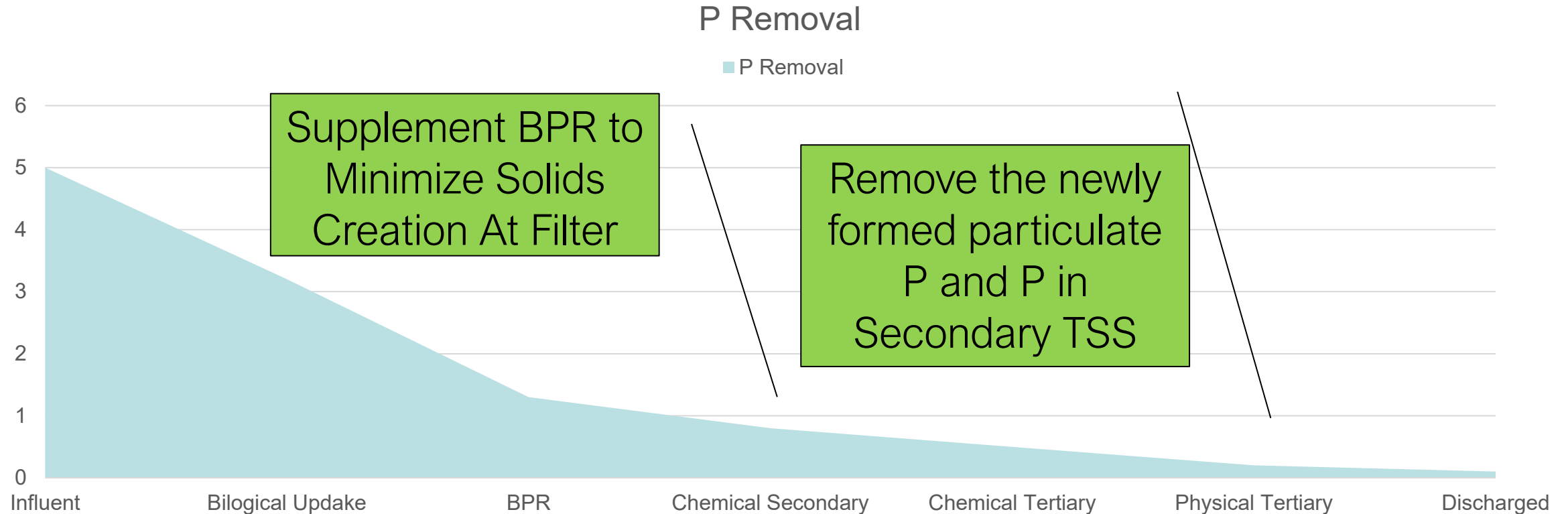

Supplement BPR to Minimize Solids Creation At Filter

Remove the newly formed particulate P and P in Secondary TSS

Manage RAS/WAS and Aeration to Maximize BPR

Last Chance to Create Particulate P from Soluble P

Operation and Optimization



Ortho Phosphate Analyzers Monitor Reactive Phosphorus While Controlling Chemical Feed Rates

Entering Filter
~ 0.12 to 0.18
mg/L PO₄-P

Leaving Filter
~ 0.01 to 0.02
mg/L PO₄-P

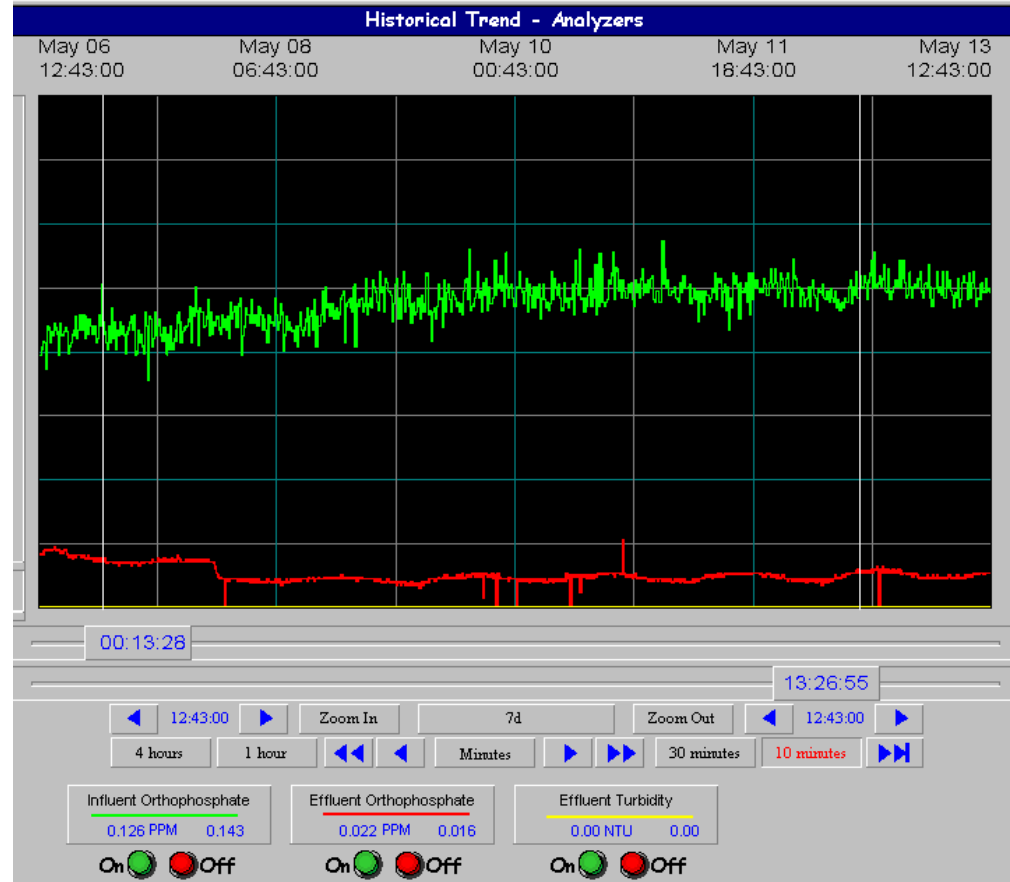

Good influent
concentration partially due
to residual chemical in the
system (by backwash) and
successful BPR

Effluent concentration
allows for some particulate
phosphorus that would not
be identified in PO₄-P
analysis

Effluent Data For First 3 Quarters Exceeded Expectations

Daily Data

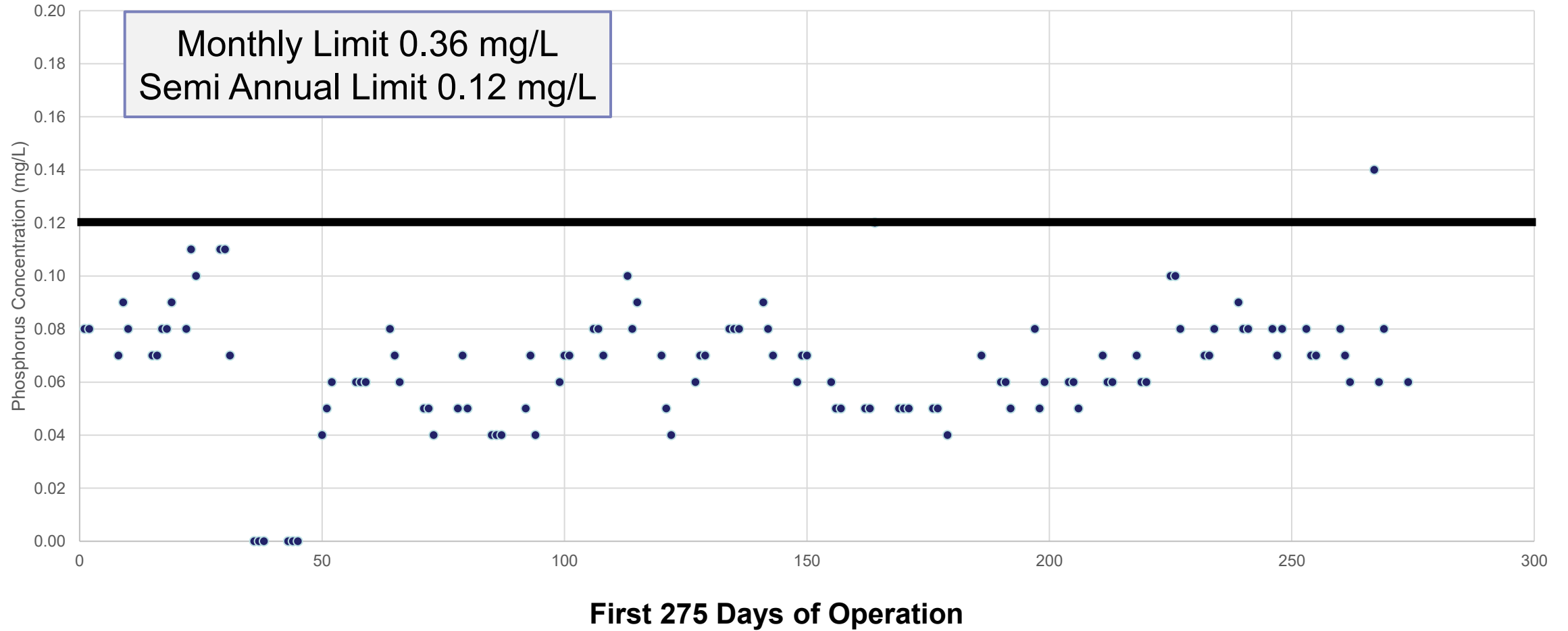

Tools Organize Data To Track Status of Monthly and Semi-Annual Limits

New Glarus - 1st half 2025

January	Eff TP		February	Eff TP		March	Eff TP		April	Eff TP		May	Eff TP		June	Eff TP	
	Day 1			Day 1			Day 1			Day 1			Day 1			Day 1	
January	2	0.07	February	2		March	2		April	2	0.07	May	2		June	2	
January	3		February	3	0.07	March	3	0.08	April	3		May	3		June	3	
January	4		February	4	0.06	March	4	0.06	April	4	0.06	May	4		June	4	
January	5		February	5	0.06	March	5	0.08	April	5		May	5		June	5	
January	6	0.06	February	6		March	6		April	6		May	6		June	6	
January	7	0.06	February	7		March	7		April	7	0.08	May	7		June	7	
January	8	0.05	February	8		March	8		April	8	0.07	May	8		June	8	
January	9		February	9		March	9		April	9	0.07	May	9		June	9	
January	10		February	10	0.10	March	10	0.08	April	10		May	10		June	10	
January	11		February	11	0.10	March	11	0.07	April	11		May	11		June	11	
January	12		February	12	0.08	March	12	0.07	April	12		May	12		June	12	
January	13	0.08	February	13		March	13		April	13		May	13		June	13	
January	14	0.05	February	14		March	14		April	14	0.07	May	14		June	14	
January	15	0.06	February	15		March	15		April	15	0.07	May	15		June	15	
January	16		February	16		March	16		April	16	0.07	May	16		June	16	
January	17		February	17	0.07	March	17	0.08	April	17		May	17		June	17	
January	18		February	18	0.07	March	18	0.07	April	18		May	18		June	18	
January	19		February	19	0.08	March	19	0.06	April	19		May	19		June	19	
January	20	0.06	February	20		March	20		April	20		May	20		June	20	
January	21	0.06	February	21		March	21		April	21	0.07	May	21		June	21	
January	22	0.05	February	22		March	22		April	22		May	22		June	22	
January	23		February	23		March	23		April	23		May	23		June	23	
January	24		February	24	0.09	March	24	0.14	April	24		May	24		June	24	
January	25		February	25	0.08	March	25	0.06	April	25		May	25		June	25	
January	26		February	26	0.08	March	26	0.08	April	26		May	26		June	26	
January	27	0.07	February	27		March	27		April	27		May	27		June	27	
January	28	0.06	February	28		March	28		April	28		May	28		June	28	
January	29	0.06				March	29		April	29		May	29		June	29	
January	30					March	30		April	30		May	30		June	30	
January	31					March	31	0.06	April	31		May	31		June	31	
Monthly Average	0.06		0.08		0.08		0.07		#DIV/0!		#DIV/0!						
	13		12		13		9		0		0						

0.072 mg/IP 6 month average
 80 Approximate Sample Days/six months
 47 Sampling Days with Data
 33 Approximate Sampling Days Remaining
 0.189 mg/L statistically allowable for remaining days

0.05 Min (mg/L P)
 0.14 Max (mg/L P)

Semi Annually
 < 0.12 mg/L P

Monthly
 < 0.36 mg/L P

Optimization of Chemical Use is Ongoing

Alum Use (gpd)

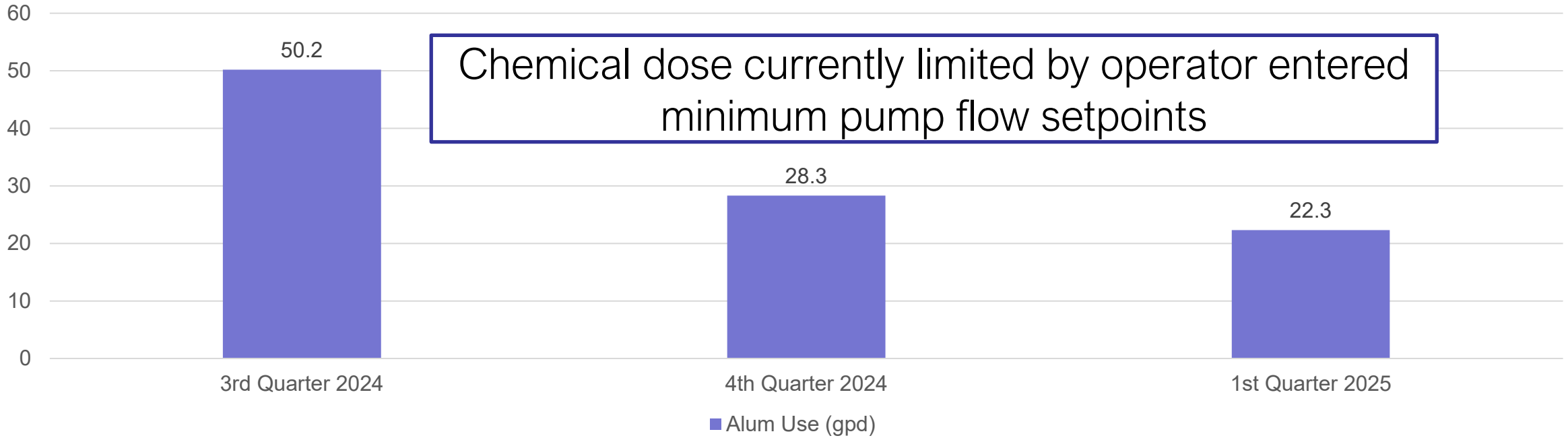

98.4 ppmv

67 ppmv

53 ppmv

Dose expressed as parts per million on a volumetric basis (ppmv)

Monitoring Aids Optimization Efforts

2025 Phosphorus

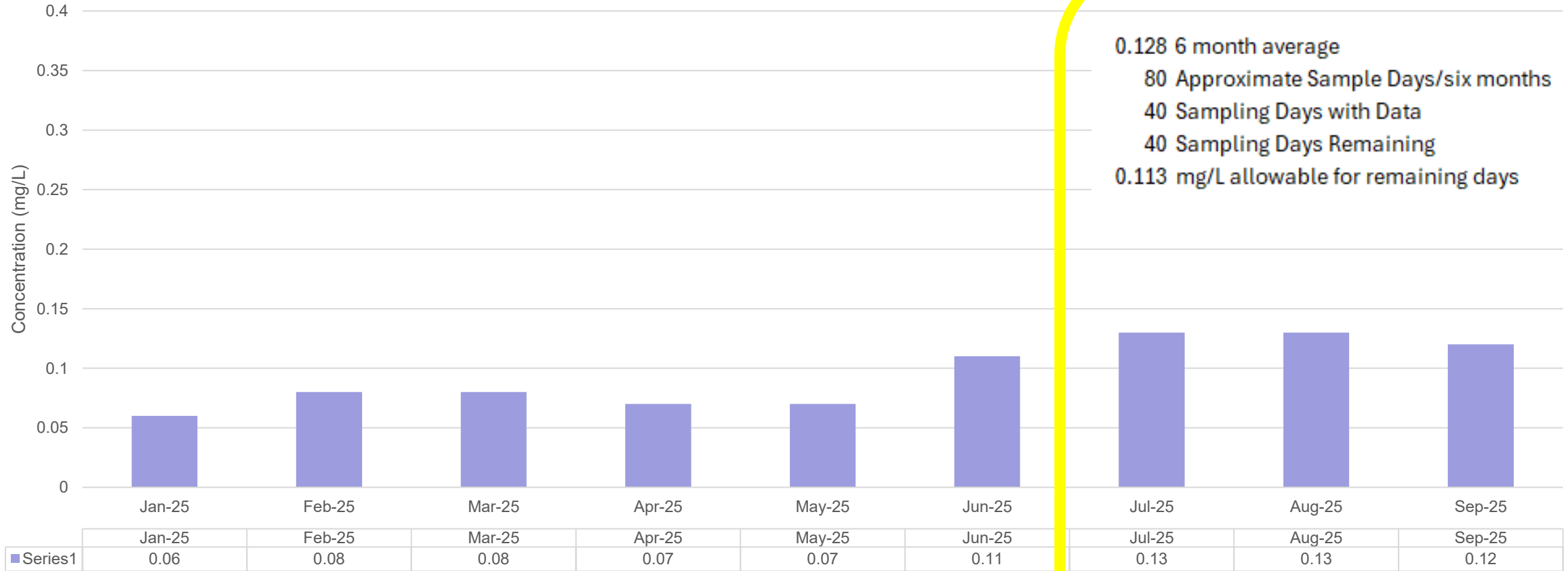

Next Steps

- Pilot polymer impacts
- Continue reducing allowable minimum in controls

Questions



© ma_rish – vectorstock.com

Introductions

Panelists

- Joel Goham – Marshfield
- Dustin Jerabek – Heart of the Valley
- Alex Zenner - Medford

Introductory Fun Facts

- Role at My Facility
- Personal Background
- Type of Facility
- Type of Filter and Date Added
- Phosphorus/TSS Limit
- Chemical Used
- Dosing Strategy

FEB
26

2026 Wisconsin Section Operations Seminar



Marshfield – Joel Goham

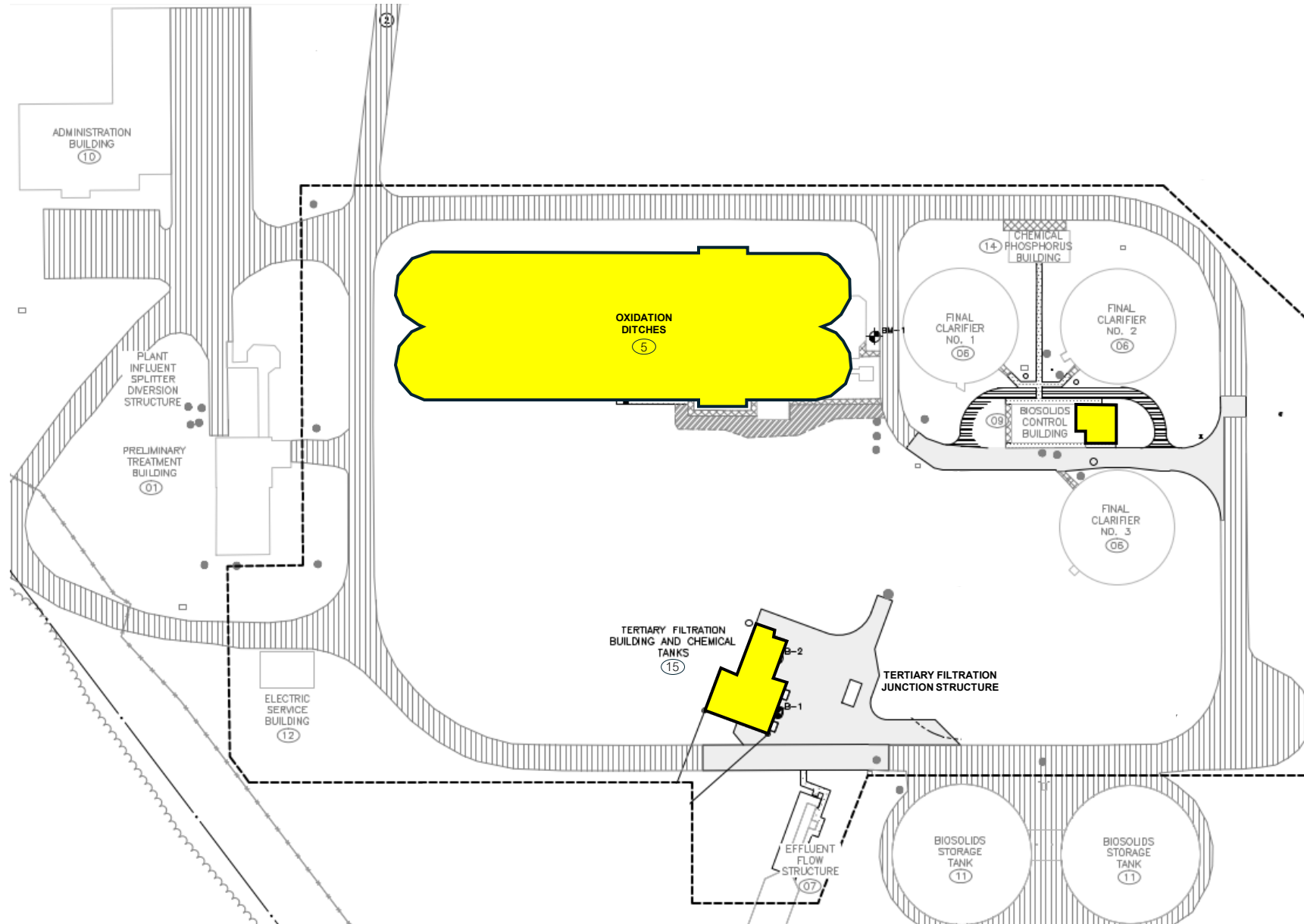

Marshfield – Joel Goham



Marshfield – Joel Goham

Post-Commissioning 4-Month Effluent TP & TSS Performance

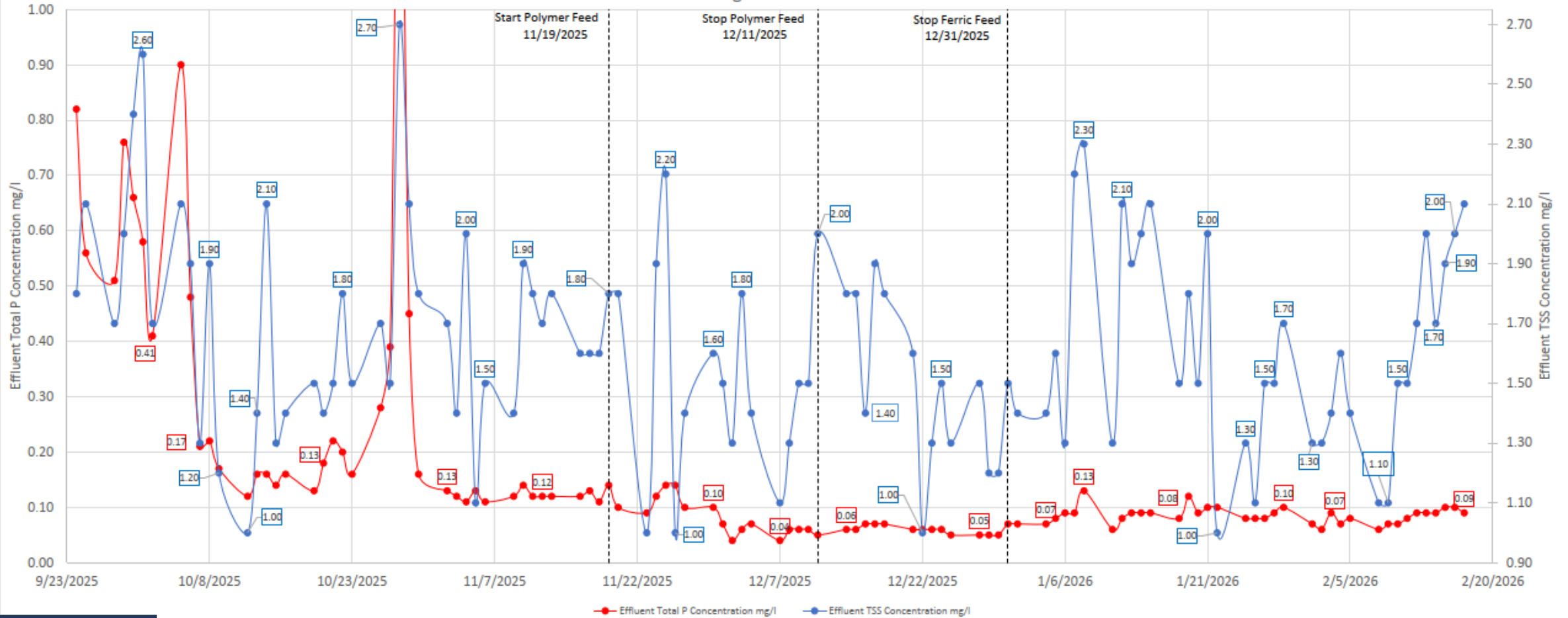

Marshfield – Joel Goham



Heart of the Valley – Dustin Jerabek



Heart of the Valley
METROPOLITAN SEWERAGE DISTRICT

Heart of the Valley – Dustin Jerabek



Heart of the Valley
METROPOLITAN SEWERAGE DISTRICT

Heart of the Valley – Dustin Jerabek



Heart of the Valley
METROPOLITAN SEWERAGE DISTRICT

Heart of the Valley – Dustin Jerabek

Disc Filter Results 2025

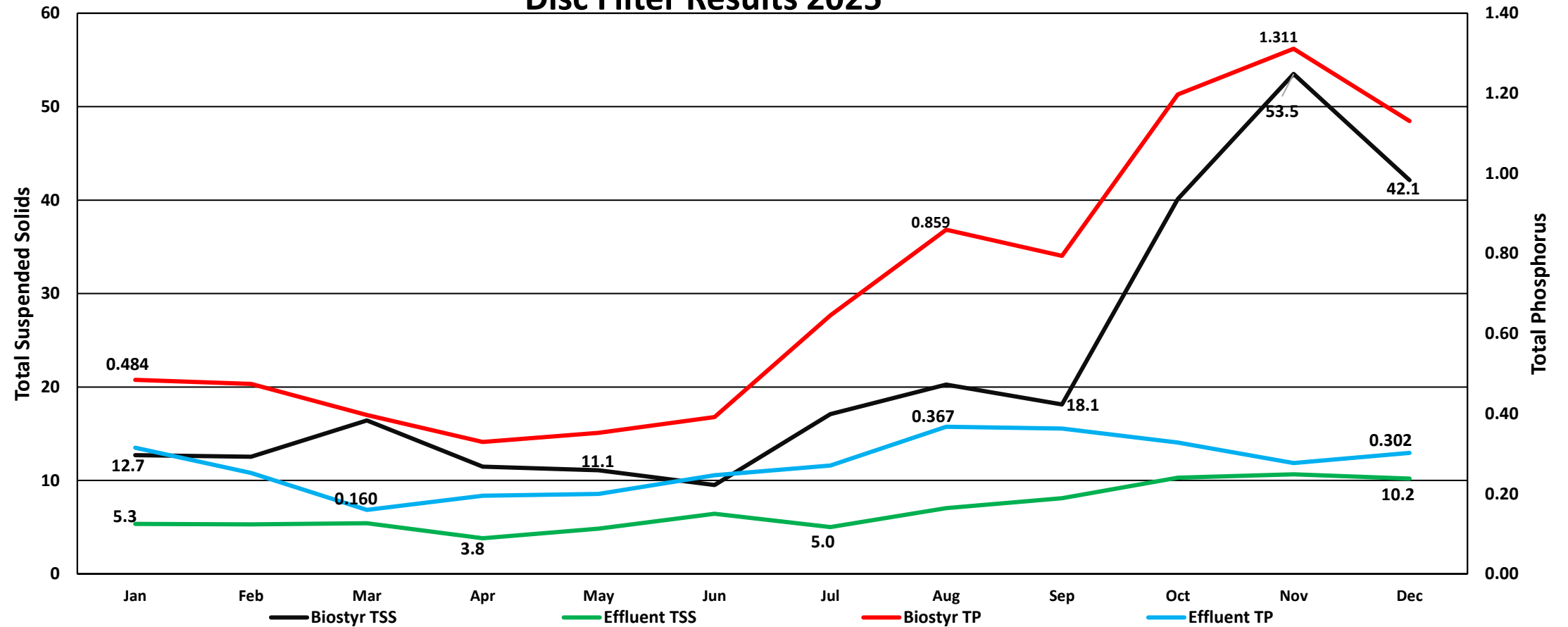

Medford – Alex Zenner



Medford – Alex Zenner

Disk filter Settings for Aluminum Sulfate

Percent Active concentration 50%

Specific gravity 1.32

Ortho Phosphate	Polymer dose mg/L	Coagulant Dose mg/L
0.00	0.85	32.00
0.03	0.90	35.00
0.07	0.95	40.00
0.50	1.00	47.00
0.85	1.20	65.00

Disk Filter Settings for ACH

Percent Active concentration 40%

Specific gravity 1.34

Ortho Phosphate	Polymer dose mg/L	Coagulant Dose mg/L
0.00	0.85	18.00
0.03	0.90	24.00
0.07	0.95	30.00
0.50	1.00	35.00
0.85	1.20	50.00

Disk Filter Settings for Ferric Sulfate

Percent Active concentration 40%

Specific gravity 1.34

Ortho Phosphate	Polymer dose mg/L	Coagulant Dose mg/L
0.00	0.85	55.00
0.03	0.90	65.00
0.07	0.95	70.00
0.50	1.00	75.00
0.85	1.20	80.00



STRAND
ASSOCIATES®

Excellence in Engineering Since 1946

